

M1-SBFF-1 Fixed Flow Chamber System

The M1-SBFF-1 Fixed Flow Chamber System automates a three-stage euthanasia cycle at the push of a button: charging, dwell time, and exhaust. At the start of a cycle, doors automatically lock and will not unlock until CO₂ evacuation is complete. Clear polycarbonate doors provide visibility while the front-loading, swing-down design offers easy cage access. The airtight, gasket sealed doors prevent gas leakage during operation. The manifold design ensures even gas distribution. The M1-SBFF-1 accommodates the full range of rodent cages from all manufacturers.

Features:

- *Compliant with AVMA Guidelines*
- After starting system, technician is free to do other work
- Programs can be customized based on facility requirements
- Automation virtually eliminates operator error
- Electronically monitored safety system prevents operation when chamber door is not properly closed
- Doors automatically lock during operation and unlock after evacuation
- Two preset times - adult and neonate



Required Accessories (choose one):



EA-550
(use with cylinders)

OR



EA-255 Inline high flow regulator for house gas or when gas cylinders are not present in room.

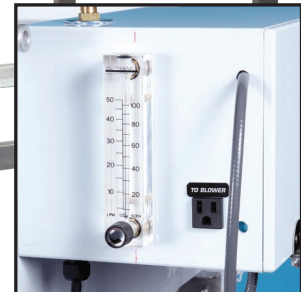

Pre-Mounted Flow Meter Included

M1-SBFF-1 includes: SMARTBOX Side Control Box, M1 Chamber, Exhaust Blower, 8 feet of 4" Exhaust Tubing, two 4" Hose Clamps (Cart sold separately.)

Optional Accessories



EA-1040



EA-1002

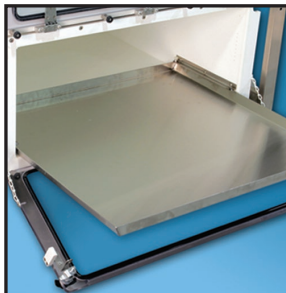

EA-5500



EZ-1336-C



EA-1315

SMARTBOX®

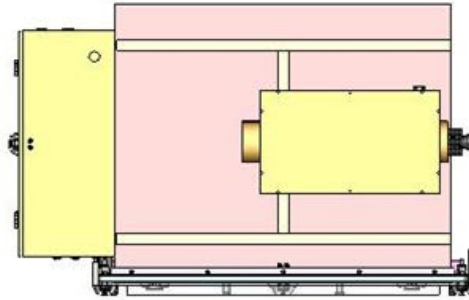

TOP VIEW

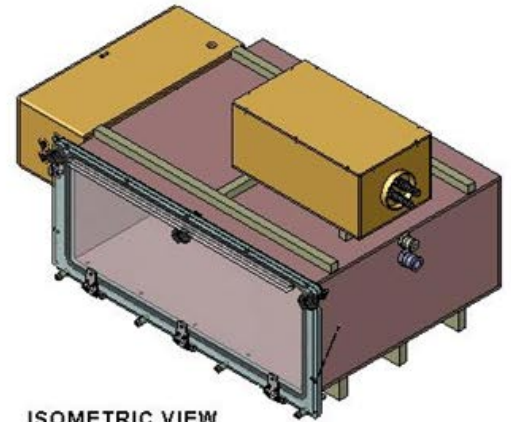

ISOMETRIC VIEW

Connects to 4" House Exhaust
-Requires 80 cfm

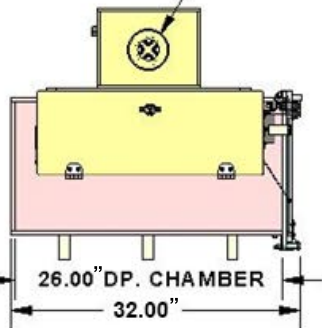

LEFT SIDE VIEW

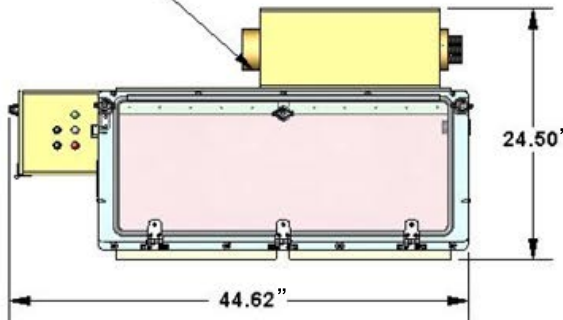

FRONT VIEW

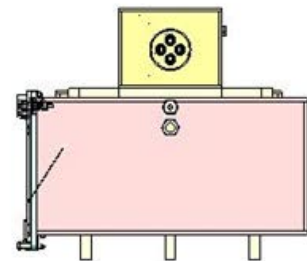

RIGHT SIDE VIEW

INSIDE CHAMBER DIMENSIONS

32.0" W X 30.5" D X 12.5" H

M1-SBFF-1 SMARTBOX CHAMBER SYSTEM

REQUIREMENTS	
ELECTRIC	120V 5 AMP
FLOW RATE	50 LPM OF CO2
4" DUCT	80 CFM